



Data sheet

IMSF-350-NAI

ID Marking Sign with floodlight

- **Ruggedized construction made for a harsh offshore environment**
- **Floodlight with standard NAI bus interface for power supply and communication**
- **Installation on standard guarding rail**
- **Low weight**
- **Low maintenance**
- **Low number of spare parts required for a fast repair**
- **Low power consumption**
- **High visibility with a minimum of light pollution**

The IMSF-350-NAI is developed for the easy night time ID marking of offshore wind turbines. The IMSF-350-NAI can be mounted on the guarding rail of the transition piece working platform so that no special fixtures are needed for the ID marking.

The IMSF-350-NAI is built up of three main components:

Mounting frame – the mounting frame is made of stainless steel 1.4404 (316L) and attached to the rail with plastic clamps to avoid damage to the rail coating. The sign board can easily be fixed to the mounting frame. The flood light is mounted on an arm which can be rotated to facilitate service for the light without dismounting the whole sign.

Floodlight – The ALS110 floodlight is a compact, ruggedized LED floodlight with optics especially designed for this application giving an absolutely spot-free illumination of the sign and nearly no light outside the sign which directly or indirectly (reflected) could disturb or blind the mariners. The floodlight is made in marine grade cast aluminium, IP67 ingress protection and an extremely low wattage for long time operation on battery based UPS.

The floodlight's integrated NAI bus interface is used to supply power and control the intensity and switching status and to transmit status and error messages to the central NAI Controller. The messages are then available to the central SCADA system.

Sign board – The sign board is made of marine grade anodize aluminium and constructed for a long life under harsh conditions e.g. high wind speed, salt and UV radiation.

The ID marking comprises Traffic Heavy type characters. The characters are yellow on black background, 350 mm high and arranged in 2 lines. The maximum number of characters per line is depending on the character width.

The sign board can easily be mounted in the bracket within a few minutes.

Technical Data

Typical Dimensions and weight

Variations available upon request.

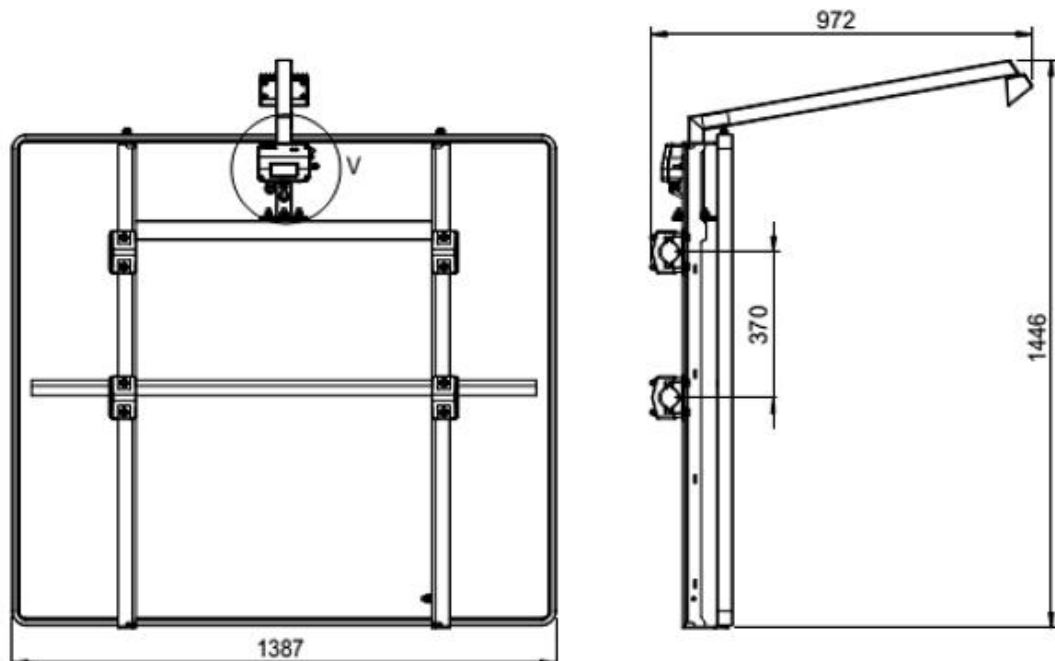

Width (mounting frame)		1387 mm
Height (overall)		1446 mm
Depth (including mounting frame)		972 mm
Weight	Arm with ALS 110 and connection socket	2 kg
	Board with maximum width	21,5 kg
	Mounting frame	12,5 kg

Electrical connection

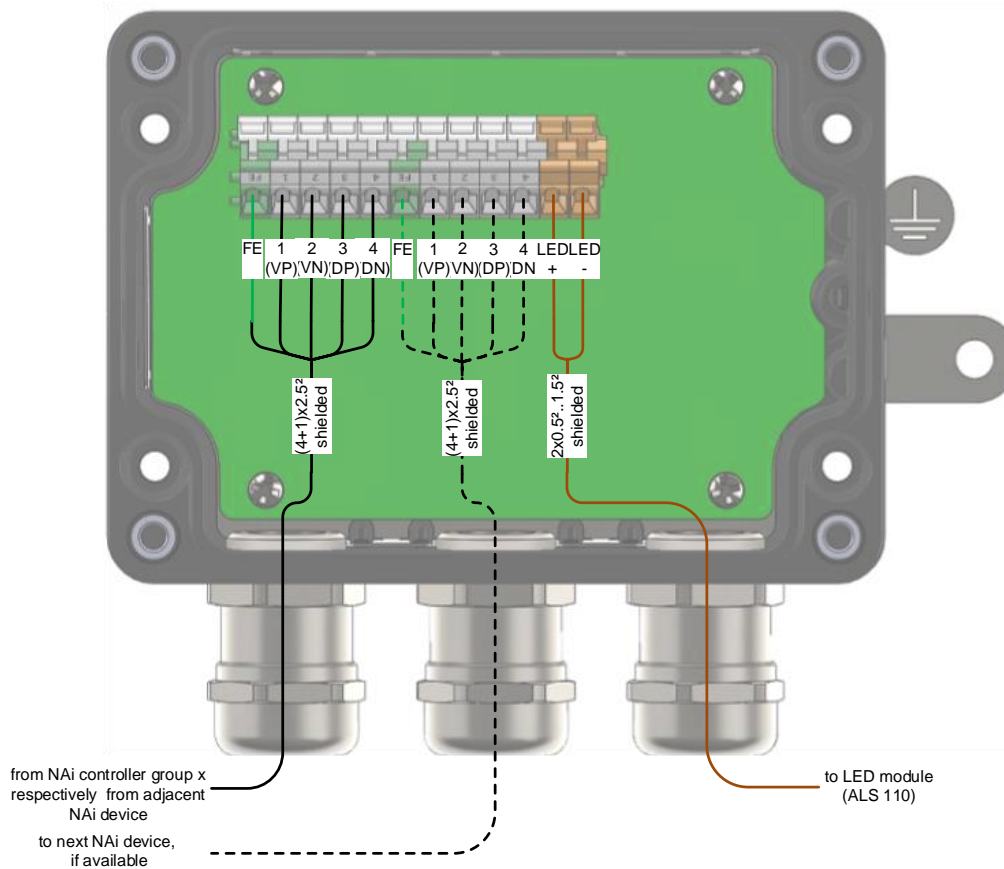

Spring terminal block electrical connection	2,5 mm ²
Operating voltage V_{IN}	19 to 36 V DC
Power consumption	2 W
EMV cable gland (M20x1,5)	Cable diameter 7,5 to 14 mm

Optical system

Light colour	3850 K
Uniformity [E_{min} : E_{max}]	better than 1 : 3

Reliability

MTBF Electronics	2 130 000 h
Minimum LED Lifetime	100 000 h

Environmental conditions

Regulations	IEC 60945, device type 'exposed'
Ambient temperature (operation)	-25 to 55 °C
Ambient temperature (storage / transport)	-40 to 70 °C
Humidity (operation / storage / transport)	max. 95 % according to IEC 60945
Atmospheric pressure (operation/storage/transport)	80 kPa bis 108 kPa
Protection degree (according to IEC 60529)	IP67
Protection class	III

Mechanical requirements

Vibration testing sinusoidal vibrations	acc. to IEC 60945
---	-------------------

EMC compliance

EMC requirements		Applied Standard	Test standard/test criteria
Emission	Radiated emission	EN 60945:2002	IEC/CISPR 16-2-3:2010 Antenna distance 3 m
Interference immunity	Electrostatic discharge (ESD)	EN 60945:2002	IEC 61000-4-2:2008 Criterion B 8 kV air discharge 6 kV contact discharge
	Electromagnetic fields	EN 60945:2002	IEC 61000-4-3:2010 Criterion A Field strength 10 V/m
	Fast transients (burst)	EN 60945:2002	IEC 61000-4-4:2012 Criterion B On NAi bus lines (VP, VN, DP, DN): Test voltage 1 kV
	High energy transients (surge)	EN 61000-6-2:2005	IEC 61000-4-5:2005 1 kV on NAi bus line (shield)
	Conducted disturbances, induced by radio-frequency fields	EN 60945:2002	IEC 61000-4-6:2008 Criterion A All lines: Test voltage 10 V

Mounting (Example)



The mounting frame comes with four threaded pins for sign board assembly. The floodlight with arm and connection socket is fastened onto the mounting frame. The mounting frame is mounted to the guarding rail.

Components

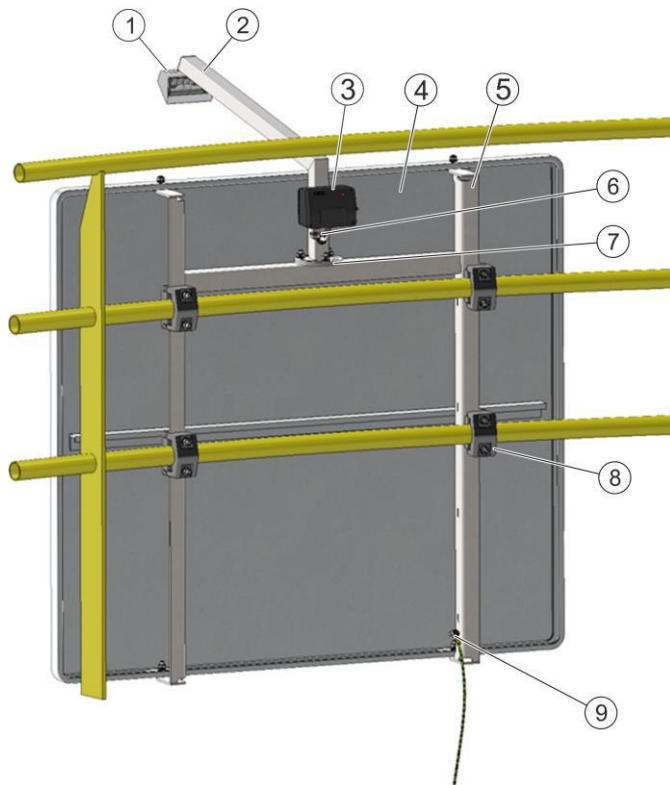

1. ALS 110
2. Arm
3. Connection socket with NAI driver, spring terminal block and EMC cable glands
4. Sign board
5. Mounting frame
6. EMC cable gland
7. Mounting plate with holes (4x M12) (part of the frame)
8. Clamps (4x) to fasten the frame to the guarding rail
9. Earthing bolt

EMC cable gland¹⁾	Dimensions M20 x 1.5	For cable diameters from 7.5 mm to 14.0 mm	Width across flats 24 mm
-------------------------------------	--------------------------------	--	------------------------------------

¹⁾ Type: HELUTOP® MS-EP4

Material

Device head	Anodised and powder coated aluminium (AlSi12)
Lenses	PMMA
Cover pane and signal window	Polycarbonate (PC)
Arm and installation plate	Stainless steel 1.4404 (316L)
Drive housing (connection socket)	PC/ABS
Cable gland	Nickel-plated brass
Earthing connection	Stainless steel 1.4404 (316L)
Seals	TPE
Pressure compensation valve for the connection box and LED insert	PTFE membrane
Sign board	AlMg3
Mounting frame	Stainless steel 1.4404 (316L)
Clamps	Polyamide (PA), glass-fibre reinforced